

DOUBLE SHEET DETECTION

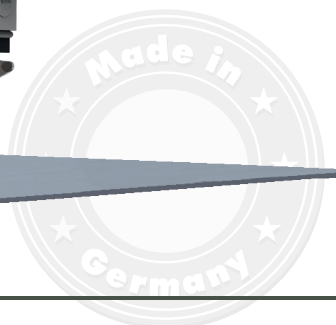

A100-S-WI DOUBLE SHEET SINGLE SIDE SYSTEM, CONTACTING

- Single probe double sheet detection system for tinplate, aluminum and non-magnetic stainless steel
- Sensor WI42GS, inductive
- Single probe measurement of
 - - Tinplate 0.15 ... 0.25 mm (0.4 mm, depending on alloy) single sheet metal thickness
 - - Aluminum 0.05 ... 0.40 mm single sheet metal thickness
 - - Non-magnetic Stainless Steel 0.50 ... 3.0 mm single sheet metal thickness
- Easy set-up by key operation or via control input
- LCD display for visualization of nominal / current values, operational / error message, key allocation
- Compact aluminum enclosure for machine frame mounting,
- Protection class IP54

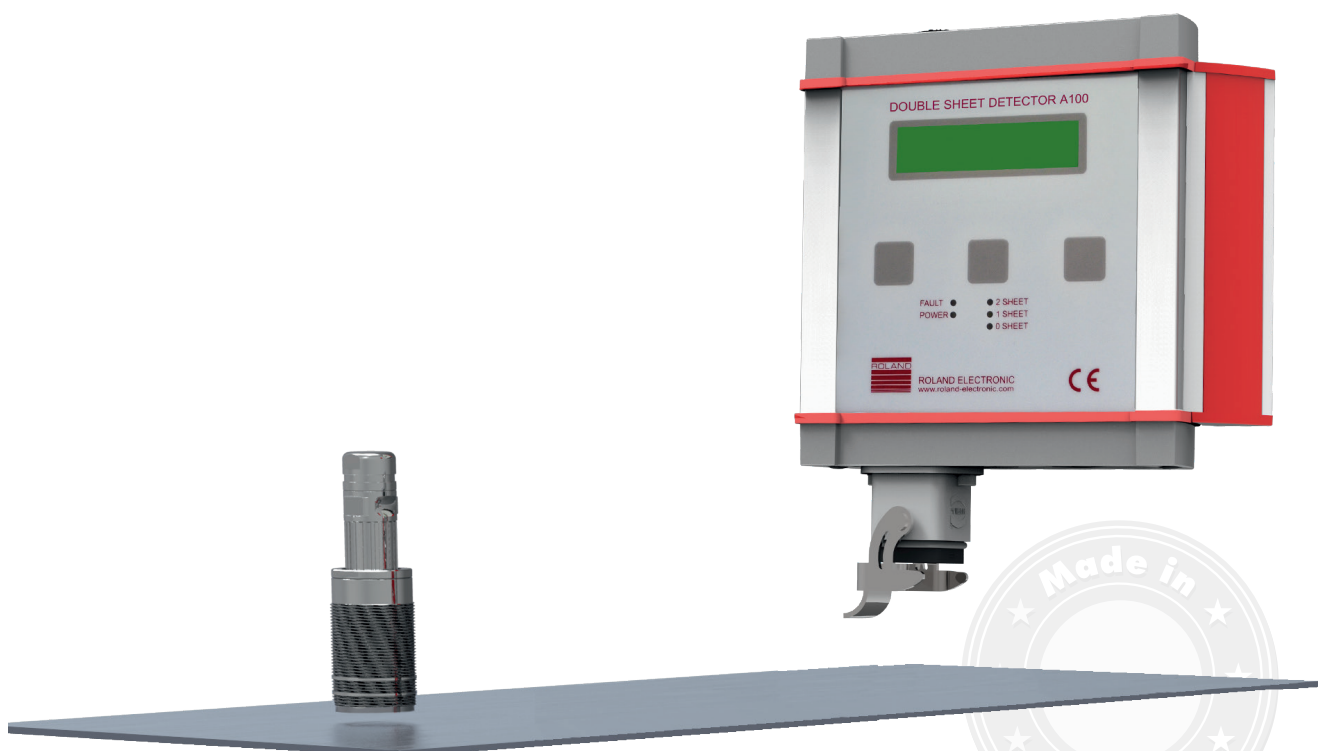

I100-S-WI DOUBLE SHEET

Description

The system consists of a sensor, a cable and the control unit. For measurement purposes the sensor is placed on the sheet. Non-contact measurement is also possible if the gap between sensor and sheet does not exceed 2 mm (.08 in.) and remains constant. The sensor can also be mounted into a spring-loaded vacuum suction cup bracket. Because of the ability to measure tinplate, thin aluminum as well as nonmagnetic stainless steel, this system has a wide range of applications.

During the production of three piece tinplate cans practically every production step has to be monitored for double blank starting with cutting the sheets in scroll shears all the way down to the filling machine monitoring for double lids.

Typically applications are found in:

- Destackers in front of sheet decorators
- Simplex and duplex shears
- Body welding machines
- Lid presses
- Filling machines monitoring for double lids
- Running can lines monitoring for the presence of easy open tabs

Application

When feeding sheets automatically, more than one sheet can be inadvertently fed into the processing machine. This can result in damage of the machine and tools, expensive repairs and production loss. The single probe Double Sheet Detector I100-S-WI has been designed to prevent such events.

Measurement principle

The system functions according to the induction principle. One sheet in front of the sensor dampens the electromagnetic field in comparison to air. An additional sheet dampens the field even further. The attenuation of the receiver signal is displayed, analyzed and issued as a 0- 1- 2 sheet signal.

Minimal operator intervention

The Teach-In process sets the upper and lower switching thresholds in such a manner that they are symmetrical in relation to the receiver voltage for one sheet. This is done with one keystroke if the material is in front of the sensor either touching it or in a constant distance of less than 2 mm. The switching thresholds are factory adjusted but can be individually modified. In case of power outage the switching threshold remain stored in memory. The adjustment procedure can also be executed via the control input.

Parameter for material and thickness

Material	Thickness	Max. air gap	Comment
Tinplate	0.15...0.25 mm (0.4 mm, depending on alloy)	2 mm	Material selection contact: open
Aluminum	0.05...0.4 mm	2 mm	Material selection contact: closed
Non-magnetic stainless steel	0.5...3 mm	2 mm	Material selection contact: open

Note: For applications with thicker materials and different alloys we recommend the use of the tried and proven R1000 series of Double Sheet Detectors with inductive or electromagnetic sensors.

Accessories:

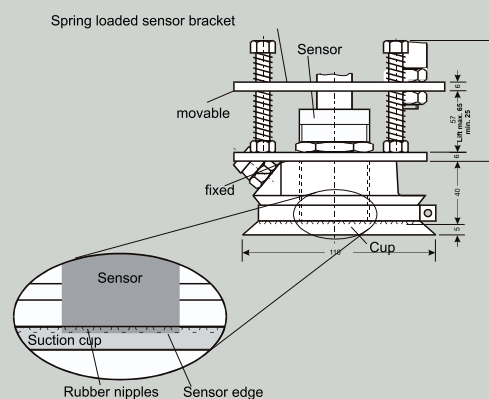

SINGLE SIDE CONTROL SYSTEM, CONTACTING

Sensor WI42GS

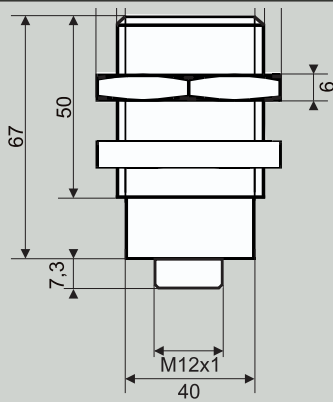

WI42GS	Sensor with terminal socket
Diameter:	Ø 42 mm
Length:	67 mm
Sensor weight:	approx. 0.30 kg / 0.70 lbs
Ambient temperature:	0° - 50°C (32° - 120° F) during operation
Protection class:	IP65

Cable SCWIS-GG

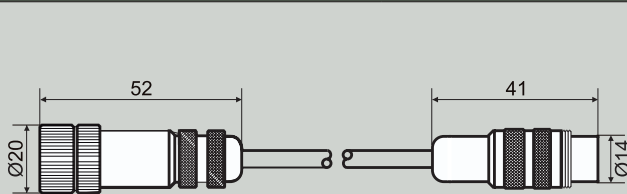

Supply plug

S0003515

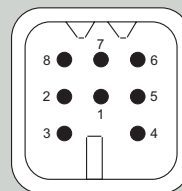

Enclosure HAN 3A,
EMI-Type,
metrical 7-pin insert and PE

Pin 1	+24VDC
Pin 2	GND
Pin 3	Teach-In
Pin 4	2-sheet
Pin 5	1-sheet
Pin 6	0-sheet
Pin 7	+24VDC from PLC
Pin 8	Earth ground

Dimensions

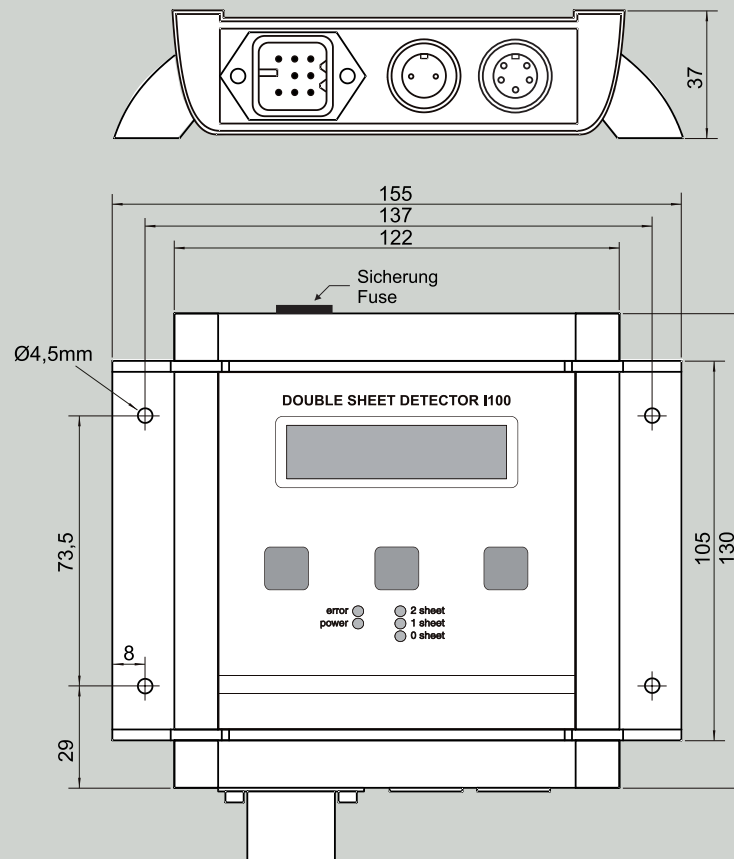

Technical Data

I100-S-WI	
Supply voltage	24 VDC (+6V / - 4V) / 110 mA
Power consumption	approx. 2.7 W @ 24V
Fuse	375 mA / slow-blow / size 5 x 20 mm
Power / Switching indication	5 LEDs
Display	LCD display, 16 characters each
Ambient temperature	0° - 50°C (32° - 122°F) during operation
Switching outputs 0-1-2 - Sheet	Opto coupler outputs, output sourcing (PNP)
Temperature drift of switching point	± 0,02% / °C
Switching capacity	max. 30 V, max 10 mA
Sensor distance	Air gap < 2 mm
Measurement period	The min. dwell time of sheet in the sensor gap is 30 ms.
Material requirements	Constant conductivity, flat and even surface
Measurement target size	Ø 40 mm (1.6 in)
Enclosure	Aluminum enclosure for screw-on mounting
Class of protection	IP54
Weight	0.6 kg (1.3 lbs)
Connections	Plug connection
Dimensions	130 x 155 x 37 mm (5.1 x 6.1 x 1.5 in) (H x W x D)

Order Information

Control unit	
Part no.	Description
I100-S-WI	Control unit, for single head sensor, operating voltage 24 V DC

Sensor	
Part no.	Description
WI42GS	Sensor with terminal socket for connecting the sensor cable (order cable SCWIS-GG separately)

Cable	
Part no.	Description
SCWIS-GG*	Sensor cable, for connecting the sensor WI42GS to the I100-S-WI control unit
* Standard cable length 5 m, larger lengths upon request.	

Accessories (for I100-S)	
Part no.	Description
S0003515	Supply plug, complete
2277706	Cable plug M12
SHS42GS	Spring mounted sensor bracket with vacuum suction cup for M42-Sensors

ROLAND ELECTRONIC GmbH

Otto-Maurer-Straße 17 75210 Keltern / Germany
phone: +49 7236 9392-0 fax: +49 7236 9392-33
info@roland-electronic.com www.roland-electronic.com

